



2MP Vandal-resistant Network IR Fixed Dome Camera



Key Feature



OPTICS

Optics

- Day/night functionality
- Smart IR technology
- Lowlight surveillance
- 3D DNR (Digital Noise Reduction)



COMPRESSION

Compression

- Triple streams
- ROI (Region of Interest)
- Customized OSD



NETWORK

Network

- ONVIF Conformance



STRUCTURE

Structure

- Support PoE power supply
- Wide temperature range: -35°C to 60°C (-31°F to 140°F)
- Wide voltage range of $\pm 25\%$
- IK10 vandal resistant
- IP66



Specifications IPC322ER-F28

Camera

| | |
|-------------------|---|
| Sensor | 1/2.8", 2 megapixel, progressive scan, CMOS |
| Lens | 2.8mm@ F1.8; Angle of View (H): 108° |
| Shutter | Auto/Manual, 1/6~1/8000 s |
| Day/Night | IR-cut filter with auto switch (ICR) |
| Min. Illumination | Colour: 0.06 Lux (F1.8, 50IRE) Black & White: 0.03 Lux (F1.8, 50IRE) |
| S/N | >52dB |
| Image Rotation | Supported |

Video

| | |
|-------------------|--|
| Max. Resolution | 1920×1080 |
| Video Compression | H.264,MJPEG |
| Frame Rate | 1080P (1920×1080): Max.30 fps; 720P (1280×720): Max. 30 fps; D1 (720×576): Max. 25 fps |
| ROI | Supported |
| Video Streaming | Triple |
| OSD | Up to 8 OSDs |
| Privacy Mask | Up to 4 areas |

Audio

| | |
|-------------------|-----------|
| Audio Compression | G.711 |
| Two-way audio | Supported |

Network

| | |
|------------------------|---|
| Protocols | L2TP,IPv4,IGMP,ICMP,ARP,TCP,UDP,DHCP,PPPoE,RTP,RTSP,Qos,NTP,FTP,HTTP,SNMP,SIP |
| Compatible Integration | ONVIF, IMOS,API |

Interface

| | |
|-----------|--|
| Audio I/O | Audio cable |
| | Input: impedance 35 kΩ; amplitude 2 V [p-p] |
| | Output: impedance 600 Ω; amplitude 2 V [p-p] |
| Alarm I/O | 1 / 1 |
| Network | 10M/100M Base-TX Ethernet |

General

| | |
|---------------------|--|
| Power | 12 V DC, or PoE (IEEE802.3 af) |
| | Power consumption: 3.5W (5.5W with IR on) |
| Dimensions (∅ x H) | ∅109 x 81 mm (∅4.3" x 3.2") |
| Weight | 0.45 kg (1.0 lb) |
| Working Environment | -35°C ~ +60°C (-31°F ~ 140°F), Humidity ≤ 90% RH(non-condensing) |
| Vandal Resistant | IK10 |
| Ingress Protection | IP66 |





Dimensions

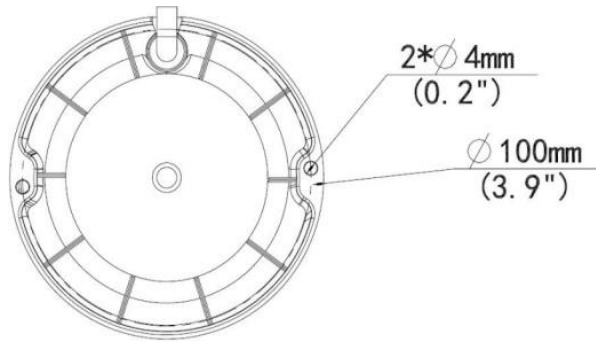
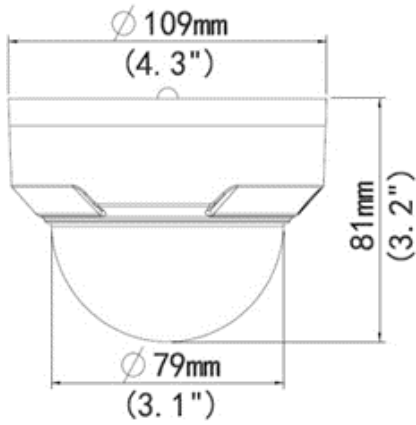

Installation

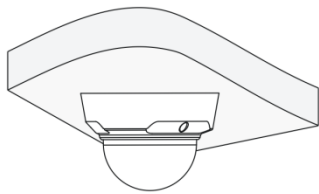

Ceiling mount

Accessories

| Installation mode | Accessories | Description |
|-------------------|--|-------------|
| Ceiling mount | Mounting pedestal is included in the Product package | \ |